



Small Bowl Cutters/Choppers K15neo • K30neo



Market Leader in the Global Food Industry



*With 7" digital touch screen and variable speed 700-3.000 rpm.
Cut and emulsify any type of meat mixture and many other food products.*

K15neo, K30neo: advantages at a glance



- 7" digital touch screen displaying knife speed, temperature, elapsed time and current time.
- Variable speed control 700 to 3.000 rpm and 4 speed preselection buttons.
- Programmable automatic stop triggered by temperature limit and/or elapsed time
- Smooth start of knives due to electronic drives, overload protection.
- Low consumption motor + drive = high efficiency.
- Emergency stop button.
- Removable 3-knife head, optionally with 6 knives.
- High quality BE-GW Steffens (Germany) knives.
- Strong, all stainless steel construction, solid s/s bowl and lid.
- Easy access maintenance covers. Adjustable, non-slip and vibration absorbing machine feet.
- Knife lid assisted with pneumatic piston (K30neo), automatic stop of the knives when opening lid.
- Transparent noise protection cover.
- Temperature sensor C/F located in cavity of lid: precise temperature measurement of mix during operation.
- Removable friction lid/bowl band for easy cleaning, with self-adjusting springs.
- Electric device to prevent condensations inside the machine frame.
- High quality, silent Poly-V drive belt.
- All screws stainless steel.
- IP65 watertight electric cabinet (K30neo).
- Bottom of machine closed.
- Easy cleaning.



7" digital touch screen.



Solid cast stainless steel bowl.
CNC precision machining.



Removable knife head with
3 knives (standard).



Optional 6-knife head.



Removable, self-adjusting
friction lid/bowl band.



Transparent noise protection cover.

Technical data



K15neo



K30neo

Technical specifications		K15neo	K30neo
Bowl capacity		15 liters (4 gallon)	30 liters (8 gallon)
Approximate batch size	soft mix	± 4-12 kg (± 9-26 lbs)	± 5-22 kg (± 11-48 lbs)
	tough mix	± 4-8 kg (± 9-18 lbs)	± 5-15 kg (± 11-33 lbs)
Machine power		2.3 kW / 3 HP	5.6 kW / 7.5 HP
Electric power type		single-phase	three-phase
Max. consumption	220/230 V	22.5 A	22.9 A
	380/400 V	-	13.2 A
Knife speed	variable	750 to 3,000 rpm	
	preselect-buttons	750 / 1,500 / 2,250 / 3,000 rpm	
Linear knife speed		9-37 m/s	12-48 m/s
Net weight approx.		± 165 kg (± 364 lbs)	± 330 kg (± 728 lbs)
Sound pressure level at 1 m		± 68 dB(A)	± 71 dB(A)
Operating temperature		+5° to +40° C (40° to 105° F)	
Recommended relative humidity level		20 to 90 %	

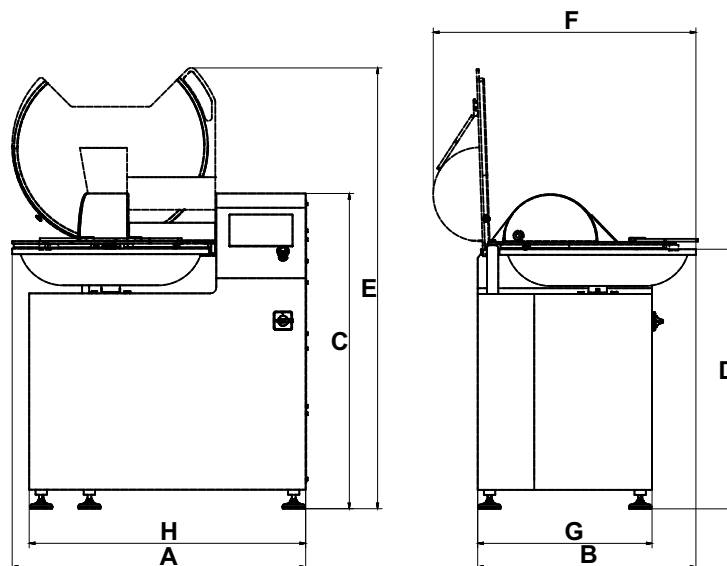

Dimensions cm (inches)	K15neo	K30neo
A	87 (34")	104 (41")
B	63 (25")	77 (31")
C	56 (22")	112 (44")
D	40 (16")	92 (36")
E	92 (36")	156 (62")
F	75 (30")	93 (37")
G	50 (20")	62 (24")
H	78 (31")	98 (39")
Packaging	102x78x75 (36x25x22")	118x104x133 (101x31x45")
Volume	0.6 m ³	1.6 m ³

Important advice: always choose large bowl cutter capacity and power, to allow the future growth of production. Available Talsa capacities: 15, 30, 50, 80, 120 and 200 liters.

TALSA, Tradition and Innovation:

35 years producing cutters.
115 years of industrial experience in machinery.
Sales and distributors in more than 60 countries.



Four generations of the Belloch family have succeeded in making what began as a small mechanical workshop founded in 1900 to serve the electrical industry, more than 100 years later an efficient industrial structure of 6000m² where attention, illusion and constant improvement is paid to every detail of our machines.

In this catalog we offer you the best of our knowledge and experience and the most modern and innovative machines, newly designed with advanced 3D software technology and R&D support from the European Union.

Thank you for your confidence.

Our product range:

- Cutters/Choppers
- Miners/Grinders
- Fillers/Stuffers
- Mixers
- Cookers/Kettles



Talsabell s.a.
Valencia - Spain
www.talsanet.com



Your authorized TALSA dealer:

Dimensions and illustrations are not binding. We reserve the right to make changes.